

HOW to **BUILD** YOUR OWN DIY

treated pine **DECKING**



[www.penrosepine.com.au](http://www.penrosepine.com.au)

# Design

## 1 The Plan

Draw the deck out in plan on graph paper and to a scale (e.g. 1 m = 5 squares). Use a grid of 2.3m or less.

## 2 Footings

Mark the points on the grid where lines intersect. These are the centres of the posts. Footings occur at these points. Holes to take the steel post brackets which are set in concrete are dug to 450mm x 450mm x 300mm deep.

## 3 Posts

Posts sizes, according to Table A1, of a height above ground of 1.8m are 100 x 100 pine treated to H5. The deck must not be higher than 3 metres from the ground.

## 4 Bearers

Bearers sizes, according to Table A2, for spacings greater than 1.8 metres and less than 3.6 metres in treated pine. 200 x 75 will give a 2.4 metre span or post spacing.

## 5 Joists

Joist sizes, according to Table A3, for spacings of 450mm in treated pine, 150 x 50 will give a 2.7m span or bearer spacing.

## 6 Decking

For floor boards use treated pine treated to H3.

## 7 Bracing

Bracing must be located on at least one corner of the deck, in two directions. Brace from post to post with double diagonals. (This means that at least four individual bracing members are necessary). For decks up to 3m high use 100 x 50mm boards, for decks below 1.8m high use 75 x 50mm braces. For decks below 1.3m high, brace from the bottom of the post to the mid-span of the bearer or joist, for both posts in the corner bays

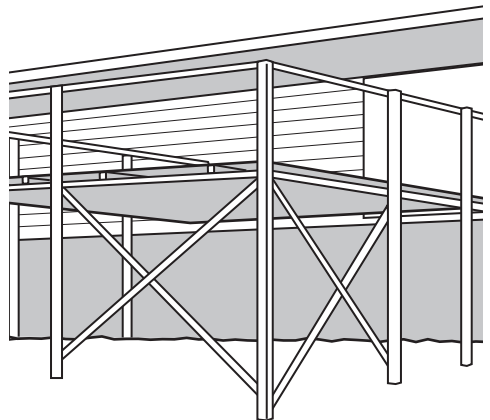

## 2 Footings and Posts

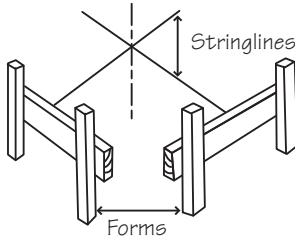

### 1 Setting Out

Set out on the ground with a string line, tape and level. Locate the corners of the deck then measure the diagonals to ensure that the structure is square. Diagonals should be equal. Use a line level to get a level string line. Measurements along this line will give the positions of posts. Vertical measurements from these points will give the height above ground. Peg these positions and make a note of their heights.

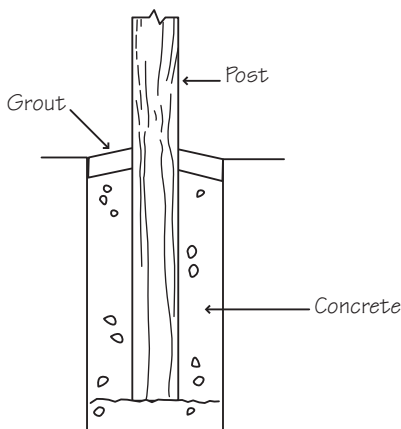

### Bracket on concrete

Posts are bolted to the steel post brackets when the concrete is at least four days old. The bolts used should be 12mm, hex-headed, galvanized mild steel. Posts should be set in over-length so that a level string line can be run through to mark the level of the bearers.

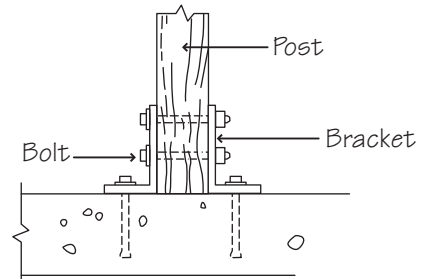

### Posts in ground

Ensure that all posts which are to be set in ground for structural support are treated to a suitable level, (H5). Post holes should be a minimum of 450mm - 500mm deep to ensure adequate support of the deck. (Depth required is dependent on the height of the deck being supported and the soil type. Consult local council requirements to ensure proper support.

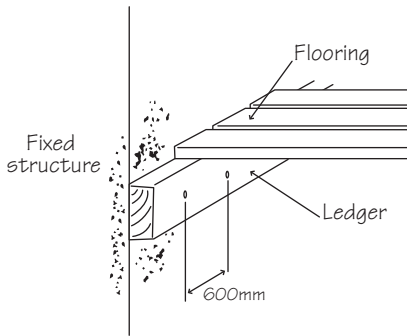

### 3 Ledgers

Where an adjacent structure is sufficiently substantial to bear the loading, a ledger can be bolted to it with masonry expanding bolts or coach screws or with hex-bolts, depending upon the situation. The ledger should be 100 x 50mm and must be fixed at a minimum of 600mm centres.

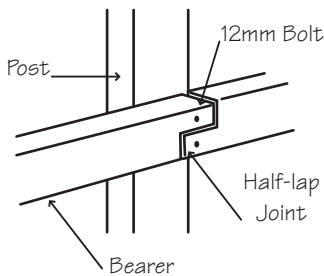

### 4 Bearers

When posts are in position, lay out the bearers on the ground beside the posts to which they relate. Mark the positions of bolt holes on the bearers so that they correspond with the centres of the posts. Cut the ends of the bearers to take a half-lap joint as shown, where necessary. Clamp the ends of the bearers on the posts at the correct level and drill through the posts at the correct level and drill through the post via the hole already made in the

bearer. Bolt up the bearer with 12mm galvanised bolts using 25mm washers. When the bearer comes to the end of the deck put it up over-length and cut it off flush with the post. You may choose to make 12mm deep checks into the posts to house in the bearer

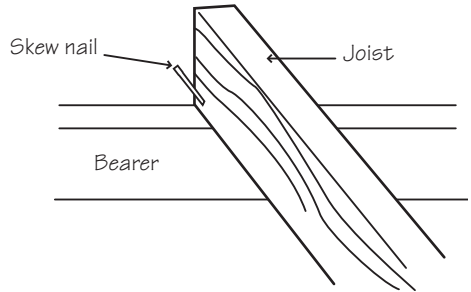

### 5 Joists

Mark the position of the joists on the bearers using a string line and tape measure. Joists must abut posts at edges. Joists to be skew nailed to bearers. Lay the joists over-length and trim off afterwards.

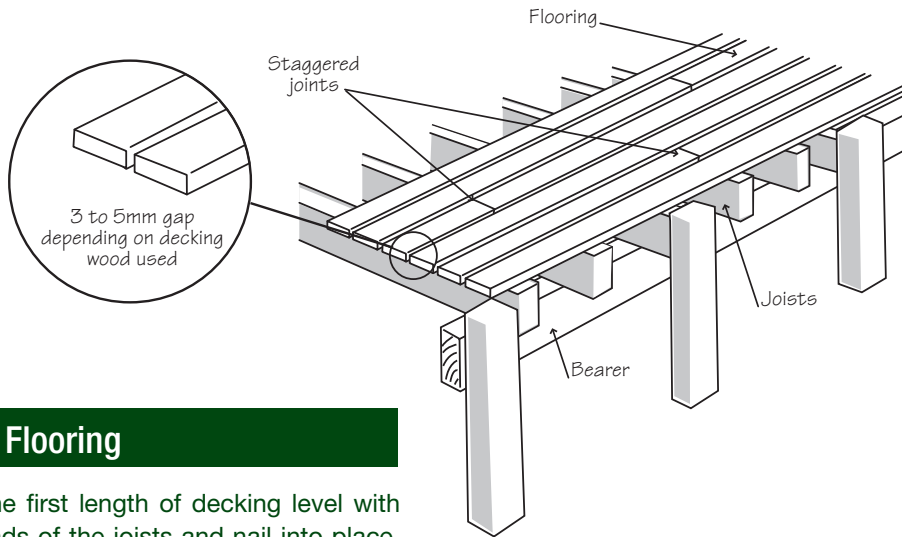

## 6 Flooring

Lay the first length of decking level with the ends of the joists and nail into place. Nail sizes shall be as specified in Table A4. Each board should have two nails at every joist and kept at least 12mm in from the board edges. Ends and joints of boards should be pre-drilled prior to nailing to avoid splitting and nails should be punched.

Make a spacer block 5mm wide for seasoned decking and 3mm wide for unseasoned decking. Use this to ensure an even spacing of board is maintained and check regularly that the boards are running true by measurement from the first board. Lay boards over length, mark cut with a string-line and trim them all off in one cut. Note: Tongue and groove flooring should not be used in weather exposed situations.

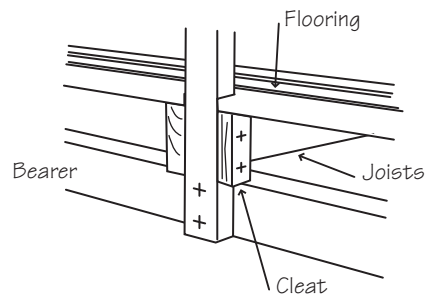

## 7 Balustrades

Handrails and balustrades should be fitted when the deck heights above ground, exceeds 915mm. The height of the handrail should not be not less than 865mm above the floor surface. This will need to be considered when determining the length of the post. Intermediate support posts may be used to reduce handrail spans. These are 50 x 75mm and are bolted to the bearers or joists with two 8mm galvanised cuphead bolts with washers. Rails are 75 x 38mm and are uprights with galvanised bolts and washers.

### Nailing instruction

All nails to be used with treated softwood joists should be deformed ring shank nails. Drills holes if necessary at 80% of nail diameter.

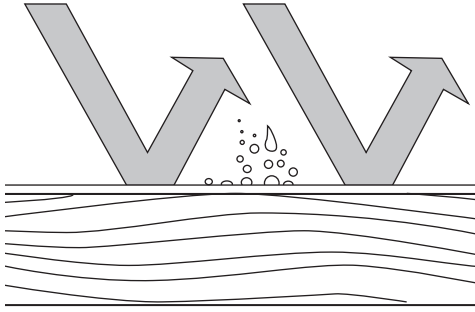

## 8 Maintenance

The long term performance of timber decking in weather exposed situations is dependant on regular and effective maintenance. The frequency of maintenance will depend on the type of finish and the degree of exposure of the deck. Before re-coating, the decking should be thoroughly cleaned and the gaps between boards, particularly over floor joists, cleared of debris.

The over watering of pot plants standing on timber decks should be avoided. It is recommended that pot plants be placed in drip trays standing on small timber cleats

---

### Timber care



Cutting, notching or boring may expose untreated heartwood.

A liberal coating of PROTIM® RESEAL is recommended to restore the protective envelope. For more details refer to the PROTIM® Timber care product literature. Raincoat UV Plus should be used to reduce the effects of weathering & maintain the appearance of your timber project.

---

Osmose Australia. makes no warranties expressed or implied or as to the fitness for a particular purpose of this plan. Check with an architect, building expert or soil engineer to make sure that this plan is appropriate for your situation and meets local building codes. A permit may be required. Read carefully the important timber information on [www.osmose.com.au](http://www.osmose.com.au) <<http://www.osmose.com.au>> regarding pressure treated wood before starting construction.

# Alternatives

The following tables give a range of alternative sizes for different spans and lengths. If you do not wish to use the deck described, then work through the tables below.

Table A1: Posts

Species	Stress Grade	Post Spacing Up to (m)	Size of Posts (mm) for Heights of (m)			
			1.2	1.8	2.4	3.0
Treated Pine	F5*	3.6	100 x 100	100 x 100	100 x 100	125 x 125

\*Sizes for treated softwood rounds: up to 2.4 high - 100mm min. dia; over 2.4 to 3.0 - 125 min dia.

Table A2: Bearers

Species	Stress Grade	Spacing of Bearers up to (m)	Size of Posts (mm) for Heights of (m)							
			1.2	1.5	1.8	2.1	2.4	2.7	3.0	3.6
Treated Pine	F5*	1.8	100x75	150x75	150x75	150x75	200x75	200x75	250x75	250x75
		3.6	150x75	150x75	200x75	250x75	250x75	300x75	300x75	NS

Table A3: Joists

Species	Stress Grade	Spacing of Joists (mm)	Size of Bearers (mm) for Spans of (m)							
			1.2	1.5	1.8	2.1	2.4	2.7	3.0	3.6
Treated Pine	F5	450	100x38	100x38	150x38	150x38	150x38	175x50	200x38	250x38
		600	100x38	125x50	150x38	150x50	175x50	175x50	225x38	250x50

Table A4: Shot Edge Decking

Species	Min Grade	Thickness (mm)	Allowable Span	Nailing Requirements
Treated Pine	Standard Grade (AS. 1782)	22	450	50 x 2.8 Galv Flat Head
		35	600	65 x 3.15 Galv Flat Head
	F5 (AS.2858)	35	600	65 x 3.15 Galv Flat Head
		45	900	75 x 3.15 Flat Head

# Important Information

1. Do not burn preserved wood.
2. Wear dust mask & goggles when cutting or sanding wood.
3. Wear gloves when working with wood.
4. Some preservative may migrate from the treated wood into soil/water or may dislodge from the treated wood surface upon contact with skin. Wash exposed skin areas thoroughly.
5. All sawdust and construction debris should be cleaned up and disposed of after construction.
6. Wash work clothes separately from other household clothing before re-use.
7. Preserved wood should not be used where it may come into direct or indirect contact with drinking water, except for uses involving incidental contact such as fresh water docks and bridges.
8. Do not use preserved wood under circumstances where the preservative may become a component of food, animal feed or beehives.
9. Do not use preserved wood as mulch.
10. Only preserved wood that is visibly clean and free of surface residue should be used.
11. Do not use preserved wood in direct contact with aluminum.
12. If the wood is to be used in an interior application and becomes wet during construction, it should be allowed to dry before being covered or enclosed.
13. Disposal Recommendations: Preserved wood may be disposed of in landfills or burned in commercial or industrial incinerators or boilers in accordance with federal, state and local regulations.
14. If you desire to apply a paint, stain, clear water repellent or other finish to your preservative treated wood, we recommend following the manufacturer's instructions and label of the finishing product. Before you start, we recommend you apply the finishing product to a small exposed test area before finishing the entire project to insure it provides the intended result before proceeding.
15. Certain metal products (including fasteners, hardware and flashing) may corrode when in direct contact with wood treated with copper-based preservatives. To prevent premature corrosion and failure it is important to follow the recommendations of the manufacturers for all metal products.
16. Mould growth can and does occur on the surface of many products, including untreated and treated wood, during prolonged surface exposure to excessive moisture conditions. To remove mould from the treated wood surface, wood should be allowed to dry. Typically, mild soap and water can be used to remove remaining surface mould. For more information visit [www.epa.gov](http://www.epa.gov).
17. For more information visit [www.osmose.com.au](http://www.osmose.com.au) / [www.osmose.co.nz](http://www.osmose.co.nz).

# guide to the HAZARD CLASSES

HAZARD CLASS	CONDITIONS	HAZARD	EXAMPLES
<b>H1</b>	Completely protected from the weather and well-ventilated	Lyctid borers	Susceptible framing, flooring, furniture and interior joinery
<b>H2</b>	Protected from wetting	Borers including termites	Framing, flooring and similar, used in dry conditions
H2F - Conditions and biological hazard as for H2 although approved for use Souther of the Tropic of Capricorn only. Example: Envelope Treatment			
H2S - Conditions and biological hazard as for H2 although approved for use Souther of the Tropic of Capricorn only. Example: LVL/Plywood (glue-line treatment)			Weatherboard, fascia, pergolas (above ground), joinery, decking & laminated verandah posts
<b>H3</b>	Subject to periodic moderate wetting	Moderate decay fungi, borers and termites	
<b>H3**</b>	Products predominantly in vertical exposed situations and intended to have the supplementary paint coat system that is regularly maintained.	Moderate decay fungi, borers and termites	Fascia, barge boards, exterior cladding, window joinery, door joinery and non laminated verandah posts
<b>H4</b>	Subject to severe wetting	Severe decay fungi, borers and termites	Fence posts, garden walls less than 1m high
<b>H5</b>	Subject to extreme wetting and/or where the critical use requires a higher degree of protection	Very severe decay fungi, borers and termites	Retaining walls, piling, house stumps, building poles and cooling tower fill
<b>H6</b>	Subject to prolonged immersion in sea water	Marine wood borers and decay fungi	Boat hulls, marine piles, jetty cross bracing and landing steps etc

Note: Please refer to the complete standards for more detailed information.

\*\* as per AS1604 and NSW TMA

\*For further information see separate brochure, consumer information and handling guide and guarantee documents. PROTIM®, RESEAL® and MoistureGuard™ are trademarks of Osmose, Inc. or its subsidiaries. © 2007 Osmose Australia # PENPDIYPERGAU\_1007.

*These plans have been checked and approved (at the time of printing) by Roy B.Hoskins & Associates of Qld 4006 (Structural & Civil Engineers), to be technically accurate and designed in accordance with the appropriate Australian Building standards, as local & National laws are subject to change, please ensure you check with your local authorities prior to starting construction.*

