

HOW to **BUILD** YOUR OWN DIY treated pine **STORAGE SHED**



www.penrosepine.com.au

Shed Erection

1

Fix bottom plates to the perimeter of the slab and bolt. Plate off-cut for door opening is used as DOOR HEAD. Untreated seasoned pine must have a damp-proof membrane laid between the timber and concrete. Use of treated pine eliminates this requirement.

2

Accurately mark all frame stations at 600 centres on the plates.

3

Stand up end wall panels and clamp on one fascia and one ridge batten. (Check for square then steady with temporary bracing).

4

Slide in the intermediate frames and fix temporarily to batten and fascia. Fix to plates with metal framing anchors. Door Head is cut and nailed in place so its bottom edge is 12mm lower than fascia. Cut and fit curtailed frame to head. (See Knee gusset detail).

5

Fit timber or metal angle bracing to both sides (not needed with ply sheeting). Fix cladding to all sides and trim with fascia, so that the top edge of the fascia follows in line with the top of roof battens. Fix battens, roofing and ridge flashing as per manufacturers specification for the roof system you have chosen. Roof sheeting should overhang the sides slightly (80mm).

6

Make a rectangle frame which will fit inside the door opening with 3-8mm clearance on all sides. Fit diagonal brace as shown and overlap cladding to give a neat appearance.

Finish and trim shed as desired. eg.:

TUDOR STYLE:

White treated pine boards with black battens

RANCH STYLE:

Treated pine weatherboards or siding, green trim

RUSTIC COLONIAL:

Treated pine shiplap or chamfer board.

NORDIC:

Diagonal treated pine chamfer board and shingle roof.

Opaque exterior paints or natural oil stains will preserve and enhance the timber claddings. To reduce heat, pale colours are preferred.

Timber care

Cutting, notching or boring may expose untreated heartwood.

A liberal coating of PROTIM® RESEAL is recommended to restore the protective envelope. For more details refer to the PROTIM® Timber care product literature. Raincoat UV Plus should be used to reduce the effects of weathering & maintain the appearance of your timber project.



KNEE GUSSET DETAIL

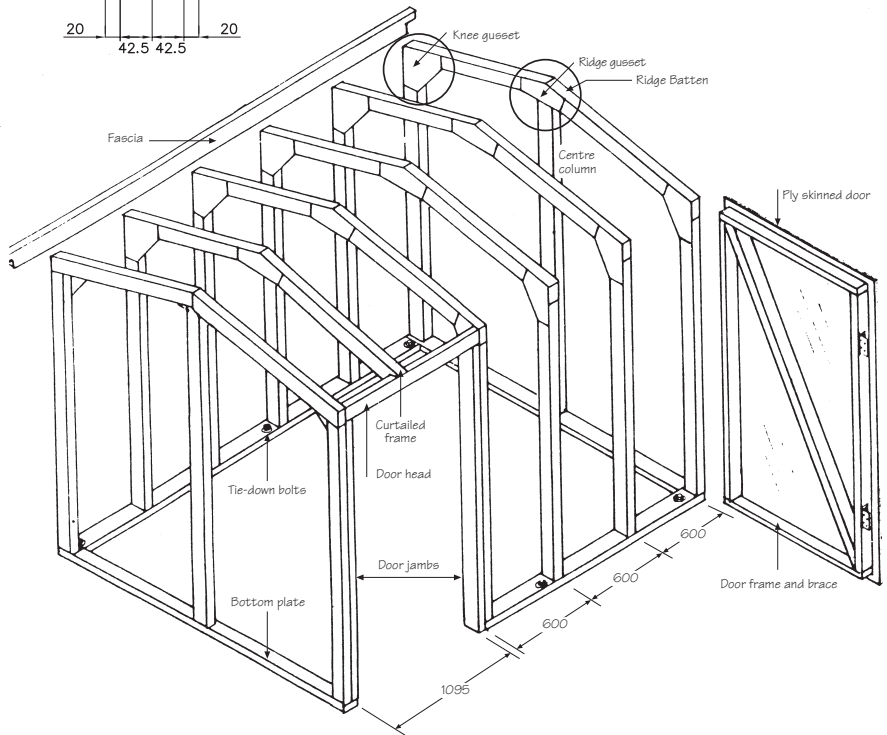
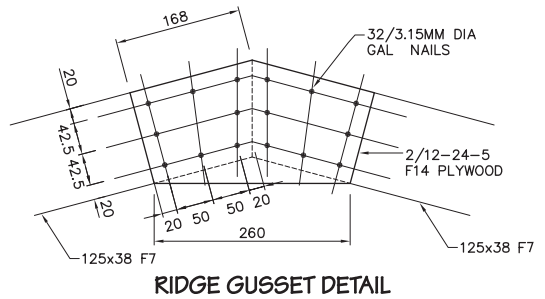
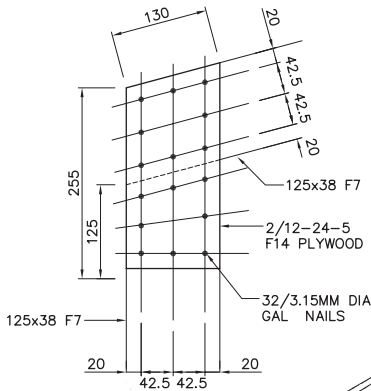

NOTE: It is essential that all sheds are tied down to foundations to prevent damage to surrounding buildings in high winds. Building approval may be required by local Council.

Osmose Australia. makes no warranties expressed or implied or as to the fitness for a particular purpose of this plan. Check with an architect, building expert or soil engineer to make sure that this plan is appropriate for your situation and meets local building codes. A permit may be required. Read carefully the important timber information on www.osmose.com.au <<http://www.osmose.com.au>> regarding pressure treated wood before starting construction.

Important Information

1. Do not burn preserved wood.
2. Wear dust mask & goggles when cutting or sanding wood.
3. Wear gloves when working with wood.
4. Some preservative may migrate from the treated wood into soil/water or may dislodge from the treated wood surface upon contact with skin. Wash exposed skin areas thoroughly.
5. All sawdust and construction debris should be cleaned up and disposed of after construction.
6. Wash work clothes separately from other household clothing before re-use.
7. Preserved wood should not be used where it may come into direct or indirect contact with drinking water, except for uses involving incidental contact such as fresh water docks and bridges.
8. Do not use preserved wood under circumstances where the preservative may become a component of food, animal feed or beehives.
9. Do not use preserved wood as mulch.
10. Only preserved wood that is visibly clean and free of surface residue should be used.
11. Do not use preserved wood in direct contact with aluminum.
12. If the wood is to be used in an interior application and becomes wet during construction, it should be allowed to dry before being covered or enclosed.
13. Disposal Recommendations: Preserved wood may be disposed of in landfills or burned in commercial or industrial incinerators or boilers in accordance with federal, state and local regulations.
14. If you desire to apply a paint, stain, clear water repellent or other finish to your preservative treated wood, we recommend following the manufacturer's instructions and label of the finishing product. Before you start, we recommend you apply the finishing product to a small exposed test area before finishing the entire project to insure it provides the intended result before proceeding.
15. Certain metal products (including fasteners, hardware and flashing) may corrode when in direct contact with wood treated with copper-based preservatives. To prevent premature corrosion and failure it is important to follow the recommendations of the manufacturers for all metal products.
16. Mould growth can and does occur on the surface of many products, including untreated and treated wood, during prolonged surface exposure to excessive moisture conditions. To remove mould from the treated wood surface, wood should be allowed to dry. Typically, mild soap and water can be used to remove remaining surface mould. For more information visit www.epa.gov.
17. For more information visit www.osmose.com.au / www.osmose.co.nz.

guide to the HAZARD CLASSES

HAZARD CLASS	CONDITIONS	HAZARD	EXAMPLES
H1	Completely protected from the weather and well-ventilated	Lyctid borers	Susceptible framing, flooring, furniture and interior joinery
H2	Protected from wetting	Borers including termites	Framing, flooring and similar, used in dry conditions
H2F - Conditions and biological hazard as for H2 although approved for use Souther of the Tropic of Capricorn only. Example: Envelope Treatment			
H2S - Conditions and biological hazard as for H2 although approved for use Souther of the Tropic of Capricorn only. Example: LVL/Plywood (glue-line treatment)			Weatherboard, fascia, pergolas (above ground), joinery, decking & laminated verandah posts
H3	Subject to periodic moderate wetting	Moderate decay fungi, borers and termites	
H3**	Products predominantly in vertical exposed situations and intended to have the supplementary paint coat system that is regularly maintained.	Moderate decay fungi, borers and termites	Fascia, barge boards, exterior cladding, window joinery, door joinery and non laminated verandah posts
H4	Subject to severe wetting	Severe decay fungi, borers and termites	Fence posts, garden walls less than 1m high
H5	Subject to extreme wetting and/or where the critical use requires a higher degree of protection	Very severe decay fungi, borers and termites	Retaining walls, piling, house stumps, building poles and cooling tower fill
H6	Subject to prolonged immersion in sea water	Marine wood borers and decay fungi	Boat hulls, marine piles, jetty cross bracing and landing steps etc

Note: Please refer to the complete standards for more detailed information.

** as per AS1604 and NSW TMA

*For further information see separate brochure, consumer information and handling guide and guarantee documents.
 PROTIM™, RESEAL™ and MoistureGuard™ are trademarks of Osmose, Inc. or its subsidiaries. © 2007 Osmose Australia # PENPDIYPERGAu_1007.

These plans have been checked and approved (at the time of printing) by Roy B.Hoskins & Associates of Qld 4006 (Structural & Civil Engineers), to be technically accurate and designed in accordance with the appropriate Australian Building standards, as local & National laws are subject to change, please ensure you check with your local authorities prior to starting construction.

